



Aboveground Tanks

Trinity Containers Aboveground Tanks have the following features:

- Available in 120-2000wg capacities
- Vacuum pre-purged to save time, money and product
- Powder coated for a durable, long-lasting finish
- Registered with the National Board
- Personalized service through our sales representatives



Utilizing over 70 years of manufacturing experience, sophisticated systems, and personal attention to detail allows Trinity Containers to provide their customers a dependable, high quality product.

TRINITY CONTAINERS, LLC AG DOMESTIC TANKS

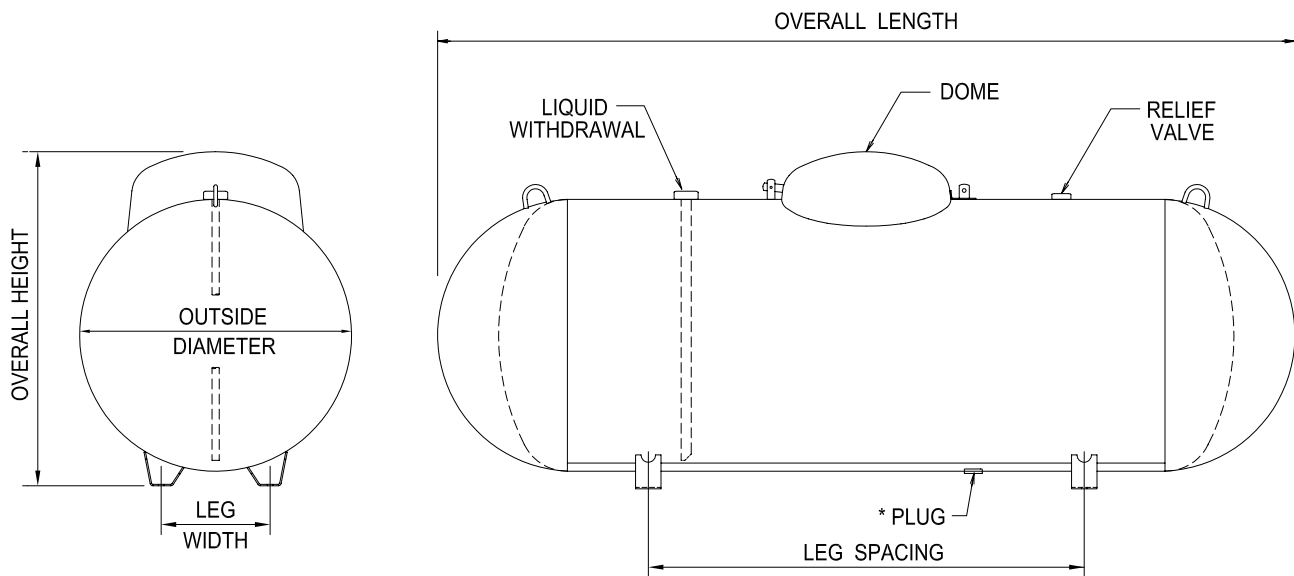

General Specifications

Conforms to the last edition and addenda of the ASME code for Pressure Vessels, Section VIII, Division 1. Complies with NFPA 58.

Rated at 250 psig from -20° F. to 125° F. All tanks may be evacuated to a full (14.7 psi) vacuum.

Vessel Finish: Coated with TGIC powder.

Liquid withdrawal opening located under the dome on the 120wg vessels ONLY.

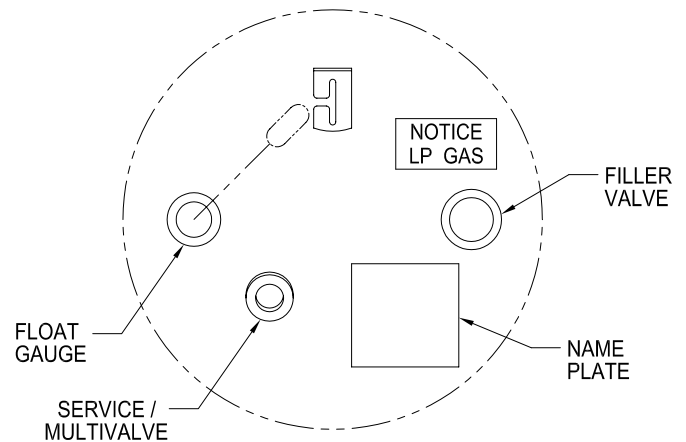

ABOVEGROUND VESSEL DIMENSIONAL INFORMATION

All vessels dimensions are approximate

WATER CAPACITY	OUTSIDE DIAMETER	HEAD TYPE	OVERALL LENGTH	OVERALL HEIGHT	LEG WIDTH	LEG SPACING	WEIGHT	QUANTITY IN FULL LOAD
* 120 wg. 454.2 L	24" 609.6 mm	Ellip	5' - 5 13/16" 1671.6 mm	2' - 8 1/4" 819.2 mm	10 1/8" 257.2 mm	3' - 0" 914.4 mm	245 lbs. 111.1 kg.	96
* 250 wg. 946.3 L	31.5" 800.1 mm	Hemi	7' - 2 1/2" 2197.1 mm	3' - 3 3/4" 1009.7 mm	12 3/4" 323.9 mm	3' - 6" 1066.8 mm	472 lbs. 214.1 kg.	63
* 320 wg. 1211.2 L	31.5" 800.1 mm	Hemi	8' - 11 3/4" 2736.9 mm	3' - 3 3/4" 1009.7 mm	12 3/4" 323.9 mm	4' - 0 1/4" 1225.6 mm	588 lbs. 266.7 kg.	45
500 wg. 1892.5 L	37.42" 950.5 mm	Hemi	9' - 10" 2997.2 mm	3' - 9 11/16" 1160.5 mm	15" 381.0 mm	5' - 0" 1524.0 mm	871 lbs. 395.1 kg	30
850 wg. 3217.3 L	40.96" 1040.4 mm	Hemi	13' - 10 7/16" 4227.5 mm	4' - 1 5/8" 1260.5 mm	16 1/4" 412.8 mm	8' - 0" 2438.4 mm	1522 lbs. 690.3 kg	15
1000 wg. 3785.0 L	40.96" 1040.4 mm	Hemi	15' - 10 13/16" 4846.6 mm	4' - 1 3/8" 1254.1 mm	16 1/4" 412.8 mm	9' - 0" 2743.2 mm	1729 lbs. 784.3 kg	15
1465 wg. 5545.0 L	46.77" 1188 mm	Ellip	17' - 6 7/8" 5356.2 mm	4' - 4 3/4" 1339.9 mm	21" 533.4 mm	10' - 0" 3048 mm	2745 lbs. 1245 kg	12
2000 wg. 7570.0 L	46.77" 1188 mm	Ellip	23' - 9" 7239 mm	4' - 7" 1709.7 mm	21" 533.4 mm	20' - 0" 6096 mm	3676 lbs. 1667.5 kg	8

* DRAIN PLUG NOT AVAILABLE